

FENDT

Fendt Katana





The power of precision: Fendt Katana forage harvester.

Forage harvesting and earning money is a lot of fun with the Fendt Katana. Because in the end it is always about performance. To be a cut above. With results that are convincing both in quality and quantity. How can you achieve this goal exactly and yet efficiently? By turning to the next page now.

The more varied the conditions, the more the Fendt Katana forage harvesters can play to their strengths. When working in grassland, it does not matter, if the terrain undulates, the ground is soft or the crop has different degrees of moisture. The Katana can manage all harvesting volumes. The huge cutterhead and the six feed rollers can process the highest yields with the best chop quality.



The Fendt Katana forage harvester also gains momentum in maize operations. Tirelessly they work their tracks. Powerful and precise, they guarantee the highest, homogeneous quality of the chopped material in any crop and in any cutting length. There is no better way to process maize for fodder or a biogas digester.

Precision is maximum performance anytime and anywhere.

The success and profitability of a biogas facility already begins in the field. Because only short, precisely processed material can provide maximum energy yield. Efficiency that is standard in the Fendt Katana 65 and 85 forage harvesters.



Numerous Fendt Katanas on the market speak for themselves. And also for the many thousand satisfied cattle for Fendt. They are our toughest critics. They sort out the overlengths in chopped fodder immediately. Valuable energy, and as a result important milk output and daily weight gains, would be lost. In order to exploit the full energy from the crop, the kernels must be cracked completely.

When your head thinks
“best chop quality”,
your heart says: Fendt.

PRECISION IN GRASSLAND OPTIONS

Can handle any situation: the Fendt Katana in grassland.

Grass is its element

With a Fendt Katana, forage harvesting becomes a secondary matter. Confident and unstoppable, the powerful engines and rugged headers work their way through different sized swathes. The feed rollers and knife drums do their job precisely. The integrated metal detector guarantees maximum safety. You only need to make yourself comfortable in the ergonomic cab.

Economical ECO mode

During grassland operations where less power is normally required under normal conditions, the strengths of the Eco drive mode come into full play. With the two-speed angular gearbox, operators can switch between Eco and Power modes according to need and save precious fuel. This is accomplished by reducing the speed of the engine from 1900 to 1520 rpm. The speed of the chopping units remains constant.

Multi-function armrest

Ergonomic, comfortable, precise: the unrivalled multi-function armrest from the Fendt tractors makes controlling the Fendt Katana forage harvester a pleasure. With the rocker switches or membrane keypad, you have the most important functions in control at all times and can control your Katana precisely with only one hand, thanks to the stringent Fendt operating logic for the hardware and software.

The 10.4" Varioterminal with colour display and touch screen (operation using rotary control and keys is also possible) is easy to operate and guarantees full machine monitoring, to keep the machine operating reliably.

From the discharge chute to the header control – the multifunction lever has the crop under control at all times. Ergonomics and short paths like in no other forage harvester.

The discharge blower is like an open rotor with v-shaped discharge elements. It can be fitted with smooth or serrated paddles, depending on the requirements.

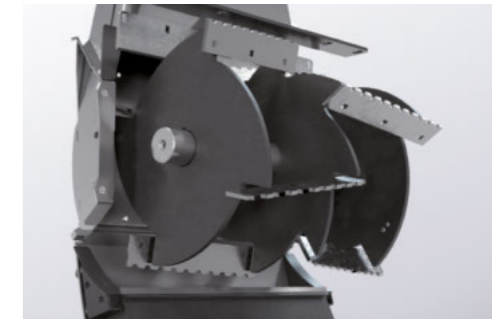

The roller pressure pad on the pick-up is easy to operate with the rocker switch on the back of the multifunction lever. It allows you to pivot the swinging frame manually in maize operations and actuate the blinker in road mode.



One push of a button is enough for Eco/Power mode to show its strength.



When driving forward, you can see the fill level of the accompanying vehicle through the camera on the discharge chute. When reversing, the image is automatically switched to the reversing camera.

VARIOGUIDE & VARIODOC PRO

Harvesting and documenting without leaving the path: Precision in whole-plant silage (GPS).

Technology, always state of the art
Benefit from continuous development: With the annual free software update from your dealer, your Fendt Katana always stays up to date, and the functionality is extended. VarioDoc Pro is already included in the VarioGuide preparation module, allowing you to extremely conveniently and reliably document all data, e.g. consumption and area coverage, and easily transfer it online to your field database. Fendt Katana is therefore ideally equipped for future requirements, So future-proof yourself.

Switch and turn off
One glance at the new Varioterminal 10.4" in tablet form says a thousand words. This irreplaceable assistant has already established itself in the Fendt tractors and combines. Now all the most important parameters have a new design and are available in your Fendt Katana forage harvester. Another plus: the steering column. Important parameters, such as diesel and AdBlue fill levels as well as the driving lights, are indicated directly on the steering column, so you do not have to look at the terminal when driving on the road.

360° ride comfort
Anticipatory driving during operation – with the Fendt Katana forage harvesters. Just like sustained ride comfort Activate the fully automatic driving mode through VarioGuide and the forage harvester goes on its way. If you would rather keeps things under control yourself: you have ideal visibility in all directions from the driver seat.

Precision from above
The Fendt Vario technologies make you faster and more precise than ever. The new Fendt Vario Guide guidance system steers your Fendt Katana in two accuracy levels, +/- 20 cm and +/- 2 cm, thereby maximising area coverage. You have a choice of two different receivers and correction services.

The Fendt documentation system VarioDoc logs all relevant data during operation.



For maximum area coverage, precise work is the key to success. The VarioGuide guidance system makes it easy for operators to achieve this.



The central indicator lights on the steering column provide information about the most important driving parameters.



The recorded information can be transferred wirelessly via Bluetooth® or data network.



In addition to the worked area in ha, a new yield measuring function records the harvested fresh mass and output.



Calibration is done through simple counter-weighing.

PRECISION IN MAIZE OPERATIONS

Fendt Katana forage harvester: the perfectionist in the maize field.



The Fendt Katana gets the most from the harvest, because every grain counts.

Maximum chopping quality

Where others bite the dust, the Fendt Katana forage harvester lays down convincing performance with its innovative wedge disc crackers. After all, a high chop quality also means higher profitability. The cutting length produced by the drum can be tailored irrespective of the application such as biogas or milk production. No matter the cutting length, the results are cracked maize kernels and an optimal crop flow, so that the energy grown in the field is well-conserved in the silo.

A true maize crack

In contrast to conventional roller crackers, the Fendt Katana forage harvester has individually swappable cracker discs. Their larger friction and pass-through surface area combined with the 20, 28 or 40-knife drum ensure maximum throughput as well as homogeneous chopped material.

Visio5 cab

One has the best view from the highest point in the terrain. That applies to the Visio5 cab as well. Its all-round windows guarantee the best sightlines. It is also markedly spacious. The ergonomic arrangement of the air-suspended seat and the control elements in the armrest are absolutely the best when it comes to comfort.

Fendt has chosen an ingenious design for the V-Cracker. By using rollers fitted with serrated discs the cracker gap length is more than doubled compared with standard rollers. If necessary, the cracker discs can be replaced individually.

The V-cracker can be quickly pivoted out of the crop flow channel electrohydraulically to a position behind the discharge blower, the grass channel is automatically brought into the correct position. This pivoting procedure can be preset in the Varioterminal and then conveniently triggered with a pushbutton located in the maintenance area, when required. That only takes a few seconds.

The new generation of the V-cracker from the Fendt Katana 85 is now also available as standard for the Fendt Katana 65.

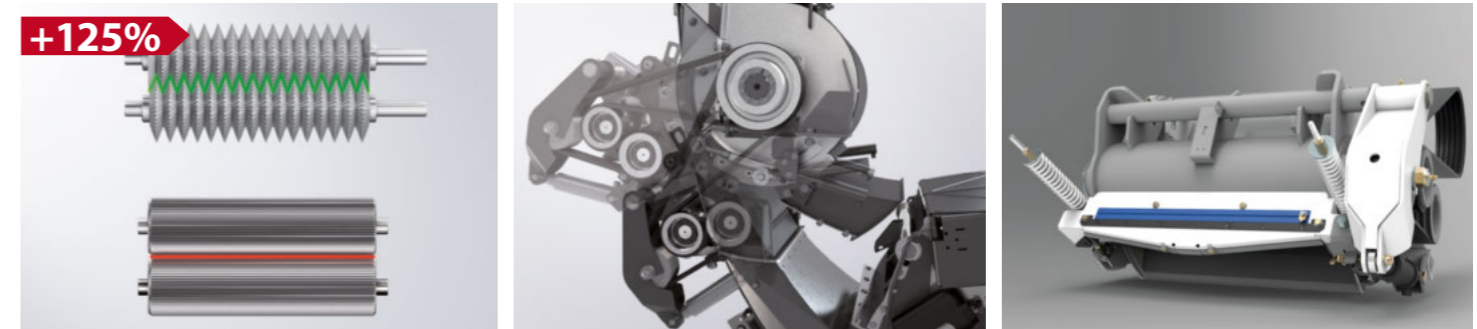

At home in maize: the harvesting season becomes a comfortable matter in the spacious Visio5 cab.

COMFORT IN MAIZE OPERATIONS

Relaxation as far as the eye can see: Your Fendt Katana in long-term operation.

Superior overview

We have equipped the Fendt Katana forage harvester with many useful extras so that you are not only surrounded by maize during the harvesting season. From innovative and straightforward operating interfaces to superior monitoring and communication interfaces, e.g. between the harvester and trailer, the Visio5 cab is anything but monotonous.

Always the right speed

With the maximum load control, the road speed is automatically adjusted to the respective harvesting and crop conditions. Engine power is optimally utilised to achieve maximum output and to make the operator's work easier. Machine utilisation is clearly displayed in the Varioterminale.

4:1 for VarioActive

Like everything in the new Fendt Katana forage harvesters, the superimposed steering system is trimmed for maximum performance. When driving on the road, four turns of the steering wheel are required for a full steering lock, at the headland with VarioActive, it only requires one turn. The result: precise steering, steady driving and extreme manoeuvrability.

The exclusive Fendt maximum output control automatically controls the forward ground speed of the Fendt Katana dependent on the crop density. The engine power is utilised optimally to achieve maximum harvesting performance.

The engine load reduction and maximum driving speed with the automatic maximum output control can be set in the terminal in order to adjust the automated function to the prevailing conditions.

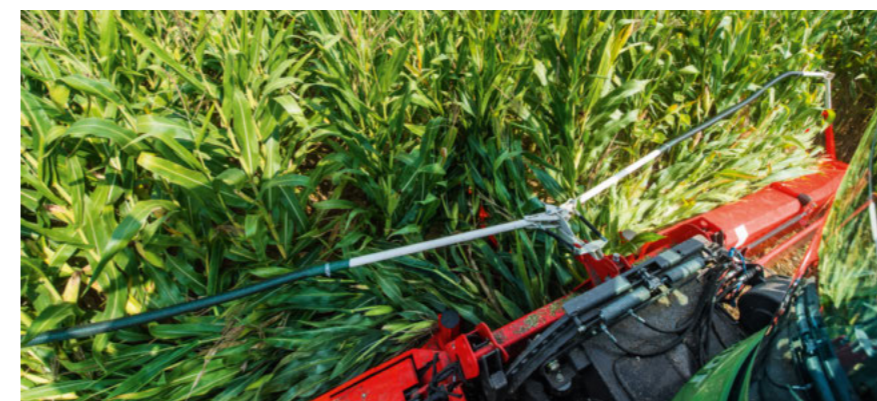

The maize header is available with eight, ten or twelve rows. For on-road driving, the header folds up hydraulically, so it can be brought into transport position quickly.

Ultra-strong LED lamps make night to day and the Fendt Katana literally to a leading forage harvester.

COMFORT

Like a bed of hay: the advantages of the Fendt Katana forage harvester.

Almost like watching TV

Fendt Katana operators find the comfort of home in their generously dimensioned Visio5 cabs: maximum comfort, the best view and, in the centre, a very comfortable easy chair. Controlling the various programs and modes is easy, just a flick of the wrist. And there is even a cool box for drinks and refreshments on board.

Illuminated comfort

The Fendt Katana forage harvester makes harvesting as enjoyable as possible. The innovative LED lighting concept shows the way safely, even in the dead of night. Uneven ground can be seen without a problem, but is hardly felt inside the cab thanks to the hydraulic rear axle suspension, either in the field or on the road.

The rear axle has suspension to absorb shock loads in the field and on the road. That protects both the operator and the machine. Furthermore, the suspension enables better ground contact for the Fendt Katana and boosts pulling power. Together with the permanent, standard specification four-wheel drive, this means optimal propulsion.



Every hand movement is right: The intuitive operation combines concentration and control.



Using the multi-function lever, the discharge chute can be quickly rotated to the other side of the machine with the touch of a button.



Even with an unloading height of up to six metres, operators have the chute flap in full view. Optionally, the discharge chute can be extended to permit the loading vehicle to be filled optimally, even with wide headers.



The combination of guidance systems and automatic maximum output control lowers the driver's workload, ensures optimal utilisation of the Fendt Katana forage harvester and permits the driver to work relaxed.

SERVICE

Nothing is as reliable as your Fendt Katana. With the exception of our service.

Diagnosis: friendly

The one-of-a-kind Fendt Service already begins with your first drive – and from then on, it is always there for you. During operation, or in the rare case of a malfunction: you are never alone in a Fendt Katana forage harvester. Unrivalled are the unique diagnostics directly in the terminal. Self-explanatory information shows parameters from the electrics and electronics, speeds, and also fault messages in full detail. That is possible through machine monitoring via CAN-bus electronics. Malfunctions can be prevented in advance, or, if the case arises, remedied as fast as possible. That increases efficiency, uptime and therefore your satisfaction.

Non-stop operational reliability

Are you familiar with our Fendt Service? You should be, because the combination of maintenance contract and extended warranty offers the highest operational reliability. In order that you can rely on your Fendt Katana forage harvester at all times, send it in for a post-harvest check to one of our national and international award winning Fendt Service partners.

100 percent service

To ensure that your Fendt Katana forage harvester delivers 100 percent performance at all times, we offer you 100 percent service. In addition to the best diagnostics-capability and ease of repair, this includes availability of replacement parts 24/7 during the harvesting season. We can guarantee that through a tight network of Fendt harvesting centres. The Fendt service network also guarantees fast lines of communication between you and our trained service employees. Any complex Service questions can be answered by the Service department in our headquarters. It can also find a fast solution to them, 100 percent.

Fendt Harvest Promise

Because during harvest time, it is important to have a partner you can count on. That is why we give you our harvest promise. We do everything to ensure your harvest is up and running:

- A widespread warehouse network for fast delivery of spare parts
- Supply of spare parts 24 hours a day, 7 days a week
- Reimbursement of costs for replacement machines



High operational reliability during the harvest with the Harvest Promise

You will receive a yearly update for the complete Fendt Katana software from your dealer. Then you can benefit from new, additional features for your Fendt. That gives you access to new operating benefits as well as a proactive retention of value, since your forage harvester is always kept up to date.



Max. hours	3,000
Max. years	1 + 4
Cover (except wear)	Full cover
Excess	✗
optional	✓

Ensure that your Fendt machine retains its value and is always ready for use with our Fendt Service benefits. Fendt offers a wide range of products to cover the repair risk on new machines. Benefit from first-class services, and from repair and maintenance services at attractive fixed prices.

MAINTENANCE & ACCESSIBILITY

Convenient and accessible: the care and maintenance points of the Fendt Katana.

Designed for comfort

The clever design of the Fendt Katana forage harvester makes maintenance work a pleasure – and ensures it is done quickly. Every location is easy to access, many components can be reached from the ground at an ideal working height. No component blocks access to important testing and cleaning areas. Even the integral ladder can be folded up, which provides the best possible access to the inner components. Even more unrestricted free space for maintenance exists thanks to the wide entrance on both sides as well as the generously dimensioned maintenance platform between the chopping assembly and engine.

Open for saving time

The fewer the required hand movements, the faster the maintenance. So don't lose any time: Open the large side flaps using the space-saving parallelogram linkage system. Remove the rear mudguard in no time flat without tools. Set the intervals for the central lubrication system conveniently from the Varioterminial. And should they ever become necessary, despite the rugged and durable construction, you will receive replacement parts within the shortest time.



Easily accessible storage and battery compartments at the rear of the vehicle offer plenty of space, for example for the optional toolbox.

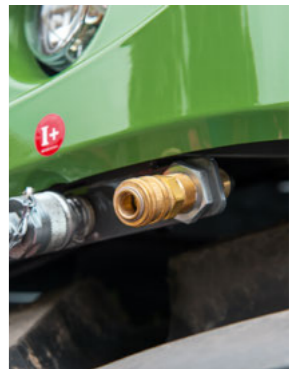

Three integrated compressed air connections permit important parts of the vehicle to be dry cleaned directly in the field.

The components on the Katana are especially easy to access thanks to large maintenance flaps, which open upwards, not sideways. The maintenance lighting makes all the difference in the dark.

EFFICIENCY

Profitability is when your Fendt Katana even cuts down the costs per hectare.

Non-stop efficiency

Compare the key data of the new Fendt Katana forage harvester and you will see: the ratio between investment and running costs, power and fuel consumption, precision and ruggedness is right. Powerful, efficient and smooth-running engines with Eco/Power mode drive the Fendt Katana 65 and 85 and comply with emissions stage Tier 4 final. In Eco mode, the engines run at 1520 rpm for a lower power requirement and reduced fuel consumption. In Power mode, the engines run with 1900 rpm for maximum power and output. In both modes, the speed of the chopping assemblies remains the same. The gearbox takes care of that: different speed input (Eco and Power), but the same output for the main belt and therefore the chopping assemblies. In addition to a low fuel requirement, wear is also low. Components were designed to be durable and tremendously ruggedly to keep the Fendt Katana constantly operational. Just what is needed during the harvesting season.

Economically economical

Beyond the claim for the highest chop quality, the Fendt Katana forage harvester has another decisive goal: overall profitability. We back up this claim by offering top-drawer advice, and through the use of ground-breaking technologies. The combination of largely dimensioned chopping assemblies and the innovative V-Cracker enables a high output. Highly efficient hydraulic drive technology and fuel saving SCR technology together with the Eco/Power modes and the automatic maximum output control, lower your costs per hectare and tonne. And cuts down unnecessary costs.

Fendt Katana 65

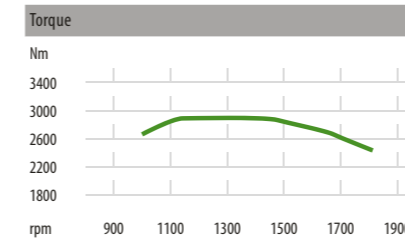

Optimal characteristic for forage harvester operations

The flat curve with the wide speed band stands for maximum power and torque – for an optimal engine speed load and maximum efficiency.

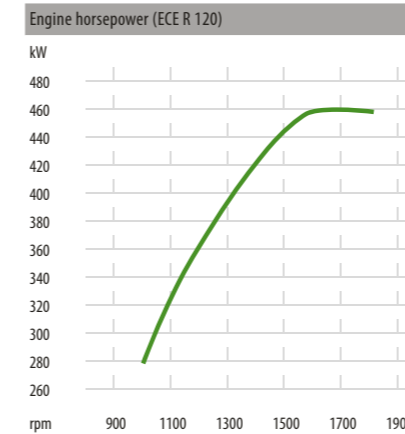

Powerful savings: If full power is required, the Fendt Katana can deliver the power required for the operating conditions. The hydrostatic drive on the Fendt Katana, together with the innovative engine technology and electronics, guarantees highly efficient operations. The front axle is driven by independent wheel motors with integral brakes. This space-saving design creates space for the all-important large-sized chopping units. Thanks to the hydrostatic drive, the speed of the header can be regulated independently and can be optimally adjusted to the prevailing conditions. The cutterhead, the V-Cracker and the discharge blower are driven by a belt drive.

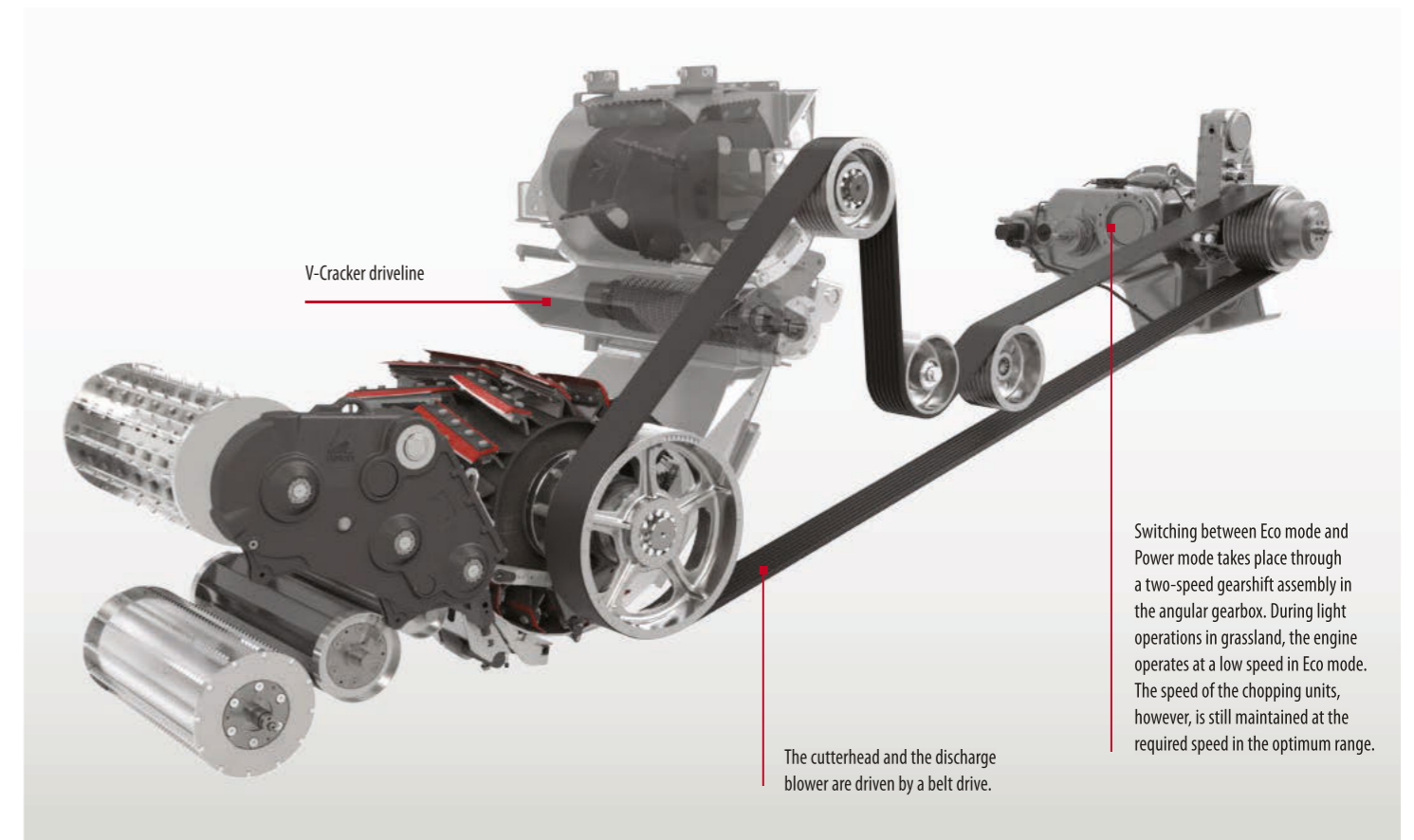

ENGINE AND TANK DESIGN

Two engines, three tanks, lots of benefits.

The variable fan on the Katana 85 draws in no more air than is needed. This releases or saves reserve capacity according to the application and the Katana power requirements, which significantly increased the machine's overall efficiency. Thanks to the fan's reverse function, dirt is pushed away from the radiator at adjustable intervals by changing the air flow. The radiator therefore always performs at its full cooling capacity and the cleaning intervals become longer.

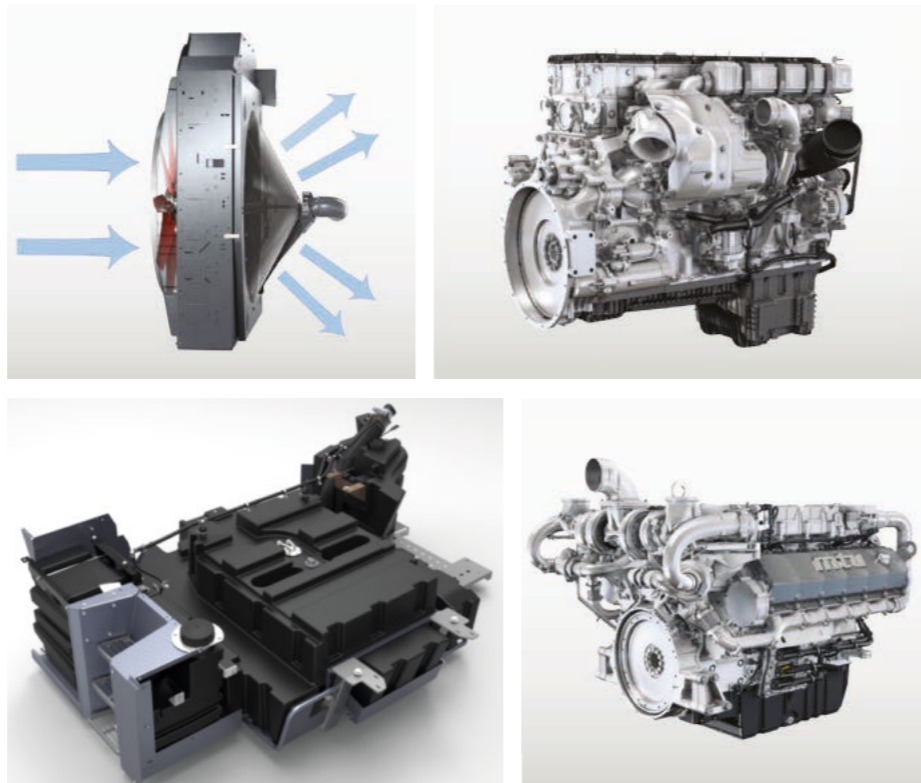

Modular & lightweight: the new tank concept

The new tanks on the Fendt Katana forage harvester not only have a high capacity – their modular and rugged plastic construction also spares a considerable amount of weight. Choose between 1225 l diesel tank with 205 l AdBlue tank or 1010 l diesel, 205 l AdBlue and 215 l water or additive tank in the Katana 65 Or decide for the Katana 85 with alternately 1430 l diesel tank or 1215 l diesel and 215 l water or additive tank. Either way you profit from the comfort of the new tank concept: the filler necks for diesel and AdBlue are located on the left side where they are easily reached.

Future-proof & economical engines

Whether the new powerful R6-MTU engine in the Katana 65 or the MTU 12-cylinder V-engine in the Katana 85, the engines in the Fendt forage harvester bring a whole host of economical and practical benefits. Despite their compact design, they unfold sufficient power at all times and ensure maximum fuel-efficiency. Furthermore, they have an especially low maintenance requirement, good accessibility, are smooth-running and already comply with emissions stage Tier 4 final today. The Fendt Katana 85 can go for 1000 hours without an oil change and does not need AdBlue or a particulate filter.

OFF-ROAD CAPABILITIES

Unearthly power on any kind of ground.

4WD standard

Intelligent and as standard: 4WD of Fendt Katana forage harvester with anti-slip control for the single wheel engines of the front axle. The differential gearbox for the suspended rear axle is driven by a hydraulic motor, where an automatic differential lock ensures the best traction when the difference in speed is too high. An HD ground drive with strong motors on the front and rear axles is available as an option for the Katana 65 for more power, torque and traction. The HD ground drive is integrated in the Katana 85 as a standard specification. The result: excellent ride comfort in any terrain.



Top manoeuvrability

The rear axle of the Fendt Katana has an excellent steering angle. Together with the compact design of the machine, this enables very high manoeuvrability. Manoeuvring is fast and easy in every situation. The design with the longitudinally mounted engine means that you can profit from an excellent steering angle.

Huge selection of tyres, first-class suspension

To protect the operator and machine from shock loads when driving in uneven terrain, the Fendt Katana forage harvesters have a height adjustable rear axle suspension. In addition to the best comfort, it guarantees additional safety and stability even at 40 km/h. Together with the new, expanded tyre selection, the Katana becomes a universal talent on any ground. Extra large tyres with diameters of up to 206 cm and width up to 900 mm lower the pressure on the ground and increase ground clearance.

SWINGING FRAME AND HEADERS

The quality of the cut is perfect from the first to last stalk.

Together with the innovative swinging frame directly on the intake, ground-contact sensors actively adapt the header to the ground contour.

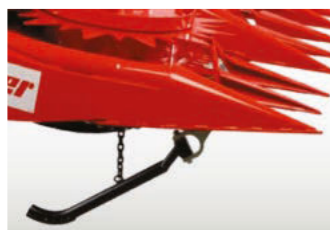

Thanks to the row sensors on the tips of the maize header, the Katana works through the crop very precisely and fully automatically.

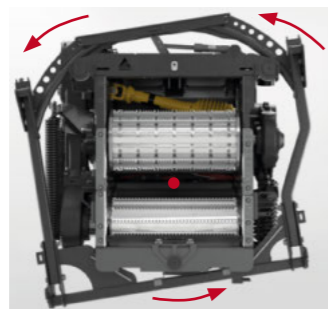

Swinging frame swung out

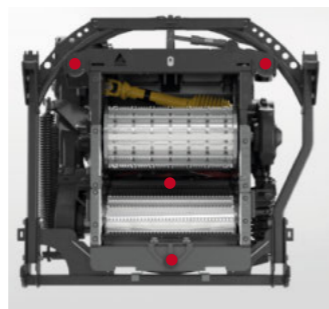

Swinging frame in middle position

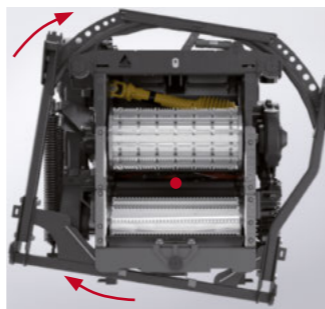

Swinging frame swung out

High-grade headers

No matter what kind of crop: the large selection of pick-ups, whole crop headers and mowers expand your operating options to a maximum. Low-wearing and maintenance-friendly, the quickly exchangeable headers perform first-class work. The uniform cutting, picking-up and feeding of the material to the feed rollers all takes place without turbulences. The continuously variable header drive permits ideal adaptation to the harvesting conditions.

More headers, more operating options

With the large selection of headers available, you and your Fendt Katana forage harvester are well-equipped for all of the established types of crops. The innovative swinging frame and the ground-contact sensors on the headers adapt themselves automatically to the changing ground contours. Because the headers have a central pivot point, the crop flow remains uniform, even when the header is tilted. All headers are attached very close to the vehicle. That reduces the front axle load and protects the soil.



The continuously variable header drive allows you to adjust the pickup speed to precisely match the harvesting conditions and the Fendt Katana forward speed.



The rugged whole crop header is designed for deep, loss-free cuts in different kinds of crops. When harvesting biomass, it delivers the best silage with a minimum of contamination.



The 360plus header with 8 small drums is lightweight and suitable for nearly all crops.



The pickup P3002 with new HD drive achieves high output even under extreme harvesting conditions. The centrally integrated feeler wheel ensures better ground following.



10 drums for up to 10 maize rows (75 cm between plants): the 375plus mower header.



With its 4 big drums, the 460plus header is ideal for difficult conditions.



With a 9000 mm working width, the 390plus is the most powerful of all Katana headers.



4 large and 2 small drums in the 475plus header can cut and feed maize plants over 4 metres high, uniformly and without difficulties.

- Grassland drum for long lengths in grass and esp. miscanthus from 5.2 – 29 mm
- Smooth running, also with very long chop lengths; optimal for loading only, when the focus is not on chopping

- Large cutting length range with one drum
- Half knife set with chop lengths of 7.4 – 41.4 mm possible without a problem
- Chop lengths von 3.7 – 20.7 mm with full knife set
- All-purpose drum for a wide range of applications

- Even shorter cutting lengths possible for improved gas yield and higher output for bio-gas facilities, 2.6 – 14.5 mm
- Higher throughput with short cutting lengths compared to standard cutterhead
- Improved compression of substrate for lower silage losses

20 Chop lengths von 5.2 – 29 mm



28 Chop lengths von 3.7 – 20.7 mm



40 Chop lengths von 2.6 – 14.5 mm



With a 720 mm diameter, the Fendt Katana has the largest cutterhead on the market. The knives arranged in a v-formation perform at up to 23,000 cuts/min. (40 knife drum), a very high cutting frequency.

- 6 feed rollers 770 mm wide for intake of high quantities of material
- Hydrostatic drive for feed rollers infinitely adjustable
- Large distance between metal detector and drum (970 mm)
- Sensitivity of the metal detector can be set to 6 levels in the terminal
- Position of foreign object is displayed in the terminal
- Activation of detector triggers warning signal as info for accompanying vehicle (enable via terminal)



Six feed rollers for effective crop feed

Crop feed over six feed rollers guarantees optimal pre-compression of the chopped material and produces high quality chopping results. The 770-mm width of the rollers permits feeding of large quantities of material. The cutting length can be infinitely adjusted from 2.6 to 42 mm, depending on the cutting drum, from the driver seat. Thanks to the independent hydrostatic header and feed roller drivelines, the header speed can be optimally adapted to the harvesting conditions. The cutting length remains constant.

Protects against foreign objects

There is a large distance between the metal detector and the cutterhead to allow for enough time to detect metal objects, even with long cutting lengths. If there are foreign objects in the feed area, the main drive automatically comes to an immediate stop, which is the reliable way to prevent cost-intensive repairs to the machine.

TYPES OF CROPS AND CROP FLOW

The more optimal the crop flow, the higher the output.

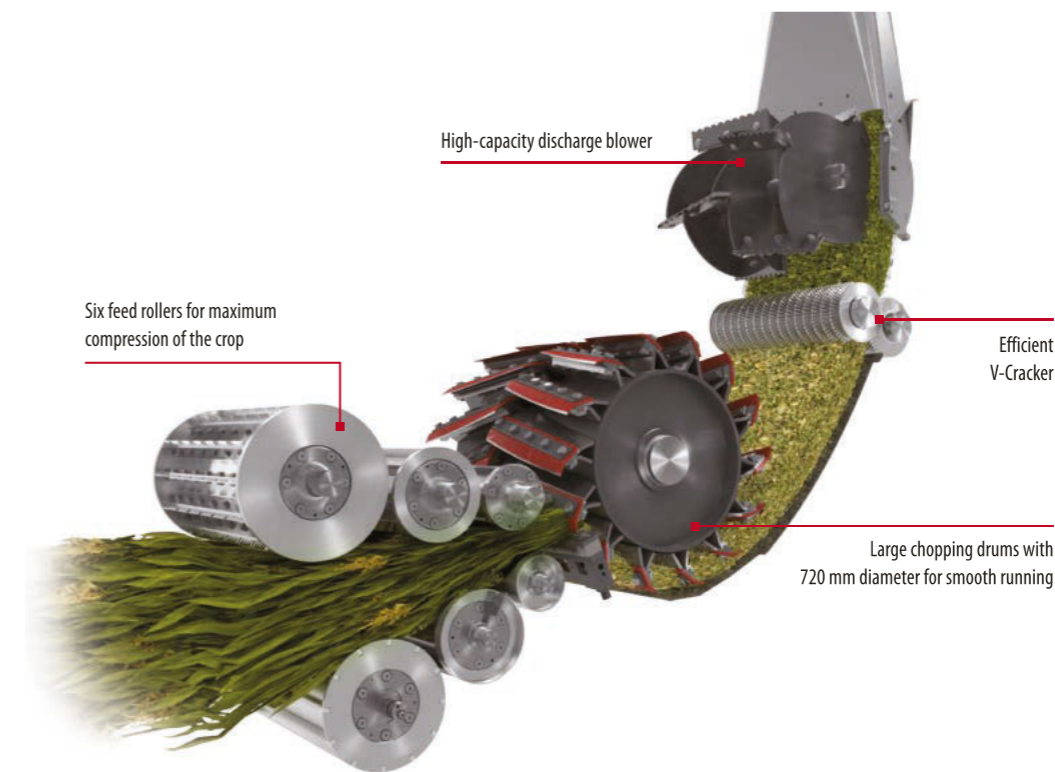

Fully integrated silage additive system

The silage additive system, which can be controlled using the Varioterminal, permits application of additives to the crop. The Varioterminal supplies information about the fill level of the tank and the current flow volumes. The silage additive is stored in an optional 215 litre tank on the right-hand side of the vehicle. By the way, you can also clean the crop flow channel using the dosing system.

Factory-installed HD wearing parts set

Wear-resistant HD components are available for the crop flow system. This way you can prolong the lifetime of wearing parts and achieve greater operational reliability during the harvest.

Perfect crop flow from intake to discharge

The perfect interplay of all components ensures a unique crop flow in the Fendt Katana forage harvesters. From the header to the feed rollers and the knife drum to the V-Cracker, all individual components are infinitely adjustable to meet your individual needs. That increases throughput, lowers wear and ensures first-class, homogeneous chopped material.

High throughput for all types of crops

Whether you're harvesting grass or maize, wet or dry crops: the six hydraulically driven feed rollers transfer the crop smoothly to the cutterhead – one of the key points in producing perfect Fendt Katana chopping quality. A great volume of material is collected here and then highly compressed. This boosts throughput and, at the same time, ensures an excellent cut of fibres, stalks and kernels of all kinds. Automatic shearbar adjustment with knife wear detection is available from now for the Fendt Katana forage harvesters.

CAB

Working and leaning back at the same time.



The Visio5 cab has been designed for optimum visibility and offers perfect ergonomics and easy-to-use controls in the workplace. Thanks to the special shape of the roof line, operators always have the chute flap in view. Automatic climate control and heating guarantee a pleasant working environment.



The practical right armrest, which is very popular with Fendt tractor drivers, has been adopted and adapted to the forage harvester.



Mp3 radio with hands-free speaking system, automatic climate control and a cooled storage compartment provide comfort on long work days.



Functions such as open/close maize header and pick-up support wheels, header tilt, lift/lower discharge chute are conveniently controlled using the toggle switches.



The drink holder, within reach of the driver, holds two bottles.



A large cool box for refreshments is located under the comfortable passenger seat.



A comfortable passenger seat comes as standard in the Fendt Katana forage harvester.

THE LIGHTING SYSTEM

Innovations as far as the eye can see.



Extensive lighting package is easy to operate.



3 pairs of work lights in the roof, driving lights in the front of the roof, side finder lights and a rotating beacon.



Powerful LED work lights on discharge chute available as an option.



For the maize harvest, in particular, one is extremely pressed for time. Here the perfect illumination of the harvesting area and machine means you can work precisely, even late at night.



Best working conditions in the dark thanks to optional LED maintenance lighting.

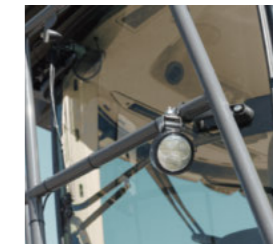

The entrance lighting helps you climb into the cab safely.



Well thought-out positioning of the LED lights facilitate work around the machine at dusk or when dark and save energy.

Its mission: power and precision. Fendt Katana 65 and 85 forage harvester

FENDT KATANA.

Equipment variants and technical details.



	Katana 65	Katana 85
Engine		
Manufacturer	MTU BR 1500	MTU BR 1600
Exhaust level Tier4final / Level 4	■	■
Engine horsepower (ECE R 120)	kW/hp 460 / 625	625 / 850
Cylinder	Number R6	V12
Cubic capacity	litres 15,6	21
Exhaust gas after-treatment	SCR	-
AdBlue tank	litres 205	-
Fuel consumption measurement	■	■
Tank capacity configuration 1 – Diesel/AdBlue	litres 1.225 / 205	1.430 / -
Tank capacity configuration 2 – Diesel/AdBlue/Additive	litres 1.010 / 205 / 215	1.215 / - / 215
Standard fan	■	■
Reversible fan		□
Maximum load control	■	■

		Katana 65	Katana 85
Ground drive			
Hydrostatic drive		■	■
4WD hydrostatic		■	■
Speed field	km/h	0 - 20	0 - 20
Road speed (max. at 1,420 rpm)	km/h	0 - 40	0 - 40
Cruise control and maximum load control		■	■
40 km/h version		■	■
25 km/h version		□	□
20 km/h version		□	□
Steering drive axle hydraulic suspension		□	
Steering drive axle rigid		■	
Steering drive axle sprung HD		□	
Steering drive axle sprung, reinforced		■	■

		Katana 65	Katana 85
Feed rollers			
Rollers	Number	6	6
Hydrostatic drive		■	■
Stepless cutting length adjustable from cab		■	■
Distance from metal detector to cutterhead	mm	620	620
Metal detector		■	■

		Katana 65	Katana 85
Cutterhead			
Shaft cutterhead continuous		■	■
Diameter	mm	720	720
Width	mm	800	800
Cutter	Number	2 x 14 (7)	2 x 14 (7)
Speed	rpm	1.150	1.150
Chop length 14 knives	mm		
Chop length 20 knives	mm	5,2 - 29,0	5,2 - 29,0
Chop length 28 knives	mm	3,7 - 20,7	3,7 - 20,7
Chop length 40 knives	mm	2,6 - 14,5	2,6 - 14,5
Cutterhead universal knives /20		□	□
Cutterhead universal knives /28		■	■
Cutterhead universal knives /40		□	□
Maize knife set /20		□	□
Maize knife set /28		□	□
Maize knife set /40		□	□
Shearbar maize		□	□
Shearbar Universal		□	□
Shearbar Universal HD		□	□
Manual shearbar adjustment		■	■
Automatic shearbar adjustment		□	□
Wearing parts set standard		■	■
Wearing parts set HD		□	□

		Katana 65	Katana 85
Kernel processing			
V-Cracker		■	■
Wedge discs / double roller		■	■
Diameter of cracker disc	mm	200	200

		Katana 65	Katana 85
Discharge blower			
Open rotor with upright v-shaped elements		■	■
Rotor diameter	mm	550	550
Rotor width	mm	620	620

		Katana 65	Katana 85
Discharge chute			
Pivot angle	Degrees	210	210
Overloading height	m	6	6
Discharge chute standard		■	■
Discharge chute extension		□	□

Available directly through AGCO Parts:



Assembly wagon for the intake for fast access to the chopping assembly. Practical construction on rollers enables easy handling.



Assembly support for easy, fast assembling and disassembling of the chopping assembly for cleaning and maintenance.



FENDT KATANA.

Equipment variants and technical details.

Standard and optional equipment
 Standard: ■
 Optional: □

	Katana 65	Katana 85
Cab		
Comfort cab with all-round vision	■	■
Driving light front	■	■
Radio preparation	■	■
Electrically adjustable external rearview mirror and wide-angle mirror	■	■
Comfort seat, air sprung	■	■
Comfort seat, air sprung Evolution	□	□
Work lights standard	■	■
All work lights LED	□	□
10.4" Varioterminal including	■	■
VarioDoc Basic	■	■
Output and yield measurement	□	□
VarioDoc Pro	□	□
Camera package	□	□
Emergency package	□	□
Radio MP3	□	□
Side work lights	□	□
LED side work lights	□	□
Maintenance lighting LED	□	□
Cooling for storage box	□	□
Wash/wipe system side and rear	■	■
Radio system for discharge chute camera	□	□
2 additional coaxial speakers	□	□
Superimposed steering system and ready for automatic steering system	■	■
Guidance system steering key	□	□
Guidance VarioGuide Controller GSM	□	□
Guidance VarioGuide Novatel	□	□
Additional equipment		
Warning device up to vehicle width 3.00m	■	■
Warning device up to vehicle width 3.30m	□	□
Warning device up to vehicle width 3.50m	□	□
Fire extinguisher	□	□
Automatic hitch	□	□
Manual hitch	□	□
Compressed air system	■	■
Fuel tank diesel plus	■	■
Fuel tank diesel and water tank	□	□
Dosing system	□	□
Preparation for dosing system	□	□
Supplement		
Protection cover for transport	□	□
Auxiliary valve da	□	□
Automatic ground-hugging	■	■
Drive shaft 1 for header Grass pickup and Kemper 400	■	■
Drive shaft 2 for header Kemper 300	■	■
Fendt Katana toolbox	□	□

Front tyres

		Katana 65	Katana 85
Front tyres, standard		800/65 R32 178A8 MT : AC70H ET-12	710/70 R42 173D TB: TM900 HP ET22
650/75R32 172A8 MT: AC70G ET 66	mm		
710/70R38 171D TB: TM800HS ET 22	mm	3200	
710/70R42 173D TB: TM900 HP ET22	mm	3200	3200
800/65R32 172A8 MI: MEGAXBIB ET -12	mm	3300	
800/65R32 172A8 MT: AC70H ET -12	mm	3300	
IF800/65R32 178A8 MI: CEREXBIB ET -12	mm	3300	
800/65R32 178A8 TB: TM2000 ET -12	mm	3300	
800/70R38 173A8 MI: MACHXBIB ET -12	mm	3300	3300
900/60R32 181A8 TB: TM2000 ET -58	mm	3500	
900/60R38 172D MT: SFT ET -58	mm	3500	3500

Rear tyres

500/80R28 176A8 MT: SVT ET 185			
600/65R28 154 D TB: TM800 HS ET 160		■	
600/65R28 154D MI: MACHXBIB ET 80		□	
600/65R28 168A8 MT: AC65 ET 80		□	
600/65R28 TB: 154 D TM800 HS ET 80		□	
600/70R34 160D TB: TM900 ET 130		□	■
620/70R30 166A8 MT: SFT ET 100		□	□
IF620/75R30 164D MI: AXIOBIB ET 100		□	□
710/55R30 MT: 162 A8 SFT ET 32		□	
710/60R30 165A8 MT: SFT ET 31		□	□

Weights and dimensions

Unladen weight with cab without header	kg	15.200	17.850
Max. permissible overall weight	kg	18.500	23.000
Overall length without header	mm	7.182	7.182
Overall width without wheels	mm	2.955	2.955
Overall width with wheels	mm	2.995 - 3.499	3.195 - 3.499
Max. overall height	mm	3.989	3.989
Wheelbase	mm	3.450	3.450
Ground clearance with max. tyres	mm	450	450

FENDT KATANA FAQs

Safety and Service non-stop.

What is the spare part availability for the Fendt Katana?

Thanks to the tight network of dealer and manufacturer parts warehouses, we can offer a widespread parts supply 24/7 during the harvesting season.

How does Fendt manage to keep my Fendt Katana working nearly without a break during the harvest?

On the one hand through a reliable product, on the other through direct and easy self-diagnostics. The convenient access to maintenance and cleaning points also saves time. If necessary, an expert from the widespread service network is available as fast as possible. The first-class factory after-sales service in Marktobendorf solves the more complex issues.

Where is the Fendt Katana developed and manufactured?

The Fendt Katana is designed in Marktobendorf (Bavaria, Germany). In tight collaboration with Fendt tractor specialists, our forage harvester experts develop fully fledged Fendt solutions from here, including everything from the vehicle to the software. The Katana is built in our modern Fendt factory in Hohenmölsen (Saxony-Anhalt, Germany), which is dedicated to forage harvesters.

How much experience is hidden in the Fendt Katana?

The Fendt Katana project already began in 2006. From the beginning, the first machines were tested thoroughly on European and North American fields and continuously further developed. In 2010 it was officially presented to the public at the Field Day in Wadenbrunn and then launched in all the major European markets. Since then, the Katana has been convincing more and more farmers and has captured an increasing share of the market from the heavy, wet grass silage in England to the high-yield maize in Italy.



Contact Fendt.

fendt.com

Here you will find everything online, from brochures to technical specifications, reports about customers or the company, up to the Fendt event calendar.

Fendt Configurator

With the Fendt Vehicle Configurator, you can choose from all the available equipment variations and put together the optimally equipped machine for your farm. The Fendt Configurator is available online at www.fendt.com, where you will find a quick link to it directly on the start page.

fendt.tv

Fendt around the clock – our Fendt Media Library makes it possible. Our internet TV provides you with news and information about Fendt 24/7.

Test drives

“Go to fendt.com and select Demonstration Service on the Service page where you may register for a test drive of your preferred Fendt vehicle.”

facebook.com/FendtGlobal

Follow us on Facebook and see what's new in the Fendt world. Come have a look!

instagram.com/fendt.global

Follow us on Instagram and become a Fendt fan. Fascinating Fendt articles are waiting for you there.

FENDT

Leaders drive Fendt!



www.fendt.com

AGCO GmbH – Fendt-Marketing
87616 Marktobendorf, Germany

 **AGCO**
Your Agriculture Company

Fendt is a worldwide brand of AGCO.
All data regarding scope of delivery, appearance, performance, dimensions and weights, fuel consumption and running costs of vehicles reflect the latest information available at the time of print. These may change by the time of purchase. Your Fendt dealer will be happy to inform you about any changes. The vehicles shown do not feature country-specific equipment.